



TECHNICAL NOTES

INSTALLATION GUIDE FOR LOW PITCH ROOFS

This installation guide is for roof pitches of 22 degrees and below

CONTENTS

Introduction	3
Underlay	4
Roof Windows	6

At a low pitch, some elements of the roof system are working at the limit of their capabilities, meaning more chance of failure under extreme weather conditions. Rather than relying on standard roofing construction, which is fine for steeper roofs, it is advisable to detail and construct the roof to protect vulnerable areas such as eaves, valleys, abutments, roof window surrounds and other such junctions.

Manufacturers rigorously test roof tiles to ensure they are fit for purpose. There will be conditions, though, when snow or rain finds its way through the tile joints; particularly where the tiles may not be seated as closely as normal as they cross over, for example, flashings. Modern vapour permeable underlays do not compress in the way that the old bituminous felts did, so they cannot seal around the batten nails quite so well. It is therefore important to install the whole roof system so that it remains watertight.

Low pitched roofs are often constructed on building extensions, where they may have to deal with water shedding from a larger roof above, sometimes in a point load through a down pipe shoe, or in concentrated loads from valleys, dormer side abutments etc. So careful design is important, with such point loads avoided if possible.

This guide details how to design and install a suitable system for use at low roof pitches.

SCOPE

Read this guide in conjunction with the installation guide, specification and other, related guides for the particular tile. All these, plus video guides and much more information, are available on our website at www.wienerberger.co.uk

Install the roof and all Sandtoft products in accordance with manufacturer's recommendations, BS 5534 and BS 5250. Carry out all site work adopting normal standards of good workmanship and in conformity with the requirements of BS 8000-6: the British Standard Code of Practice for workmanship on building sites.

ROOF CONSTRUCTION

Ideally, the roof should be boarded, but it is recognised that this is not common practice in many parts of the UK, therefore this guide assumes that the roof is not boarded. It assumes that the rafters are spaced at no more than 600mm centres and the tile battens fixed into the rafters through counterbattens.

TILING

For detailed information on installing the roof tiles and fittings, refer to the installation guide for the particular tile at www.wienerberger.co.uk

ROOF SYSTEMS

For detailed information on installing dry fix and ventilation systems, refer to the installation guide for the particular system. Video guides are also available on all Sandtoft systems at www.wienerberger.co.uk

UNDERLAY

Lay Sandtoft VPM Super underlay (Product Ref: 6100028) horizontally over the rafters with a 10mm drape between each rafter.

Allow a minimum 150mm horizontal lap between courses and minimum 100mm vertical laps.

If necessary, increase the horizontal lap to coincide with a tile batten.

Ensure there are no cuts, tears or perforations generally in the underlay.

Repair any that do occur using Sandtoft Multi-tape (Product Ref: 6180006) or discard and replace as necessary.

Seal all laps using Sandtoft double-sided tape (Product Ref: 6180008). Seal all roof junctions using Sandtoft Multi tape.

(For further information read the Sandtoft installation guide for Sandtoft VPM Super)

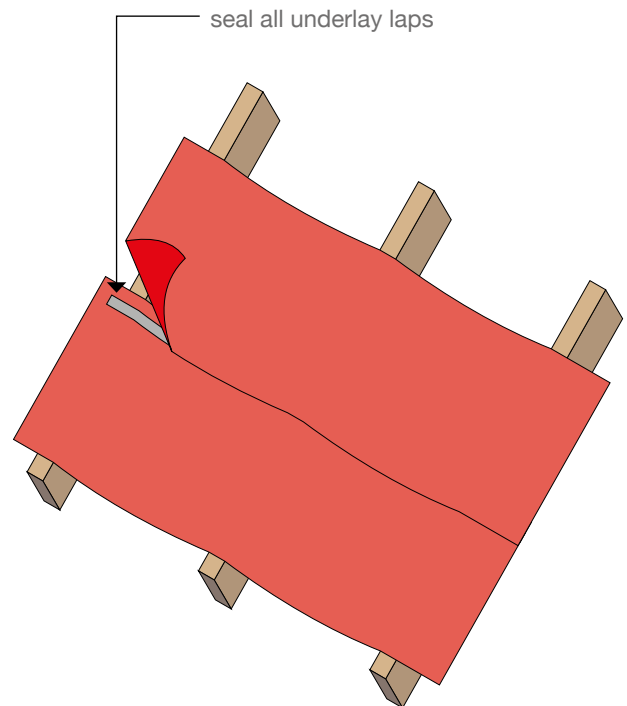

BATTENS

Lay Sandtoft butyl nail tape (Product Ref: 6180010) over the underlay, coinciding with the rafters and any other fixing points.

Remove backing tape then fix counterbattens over the nail tape and rafters, fixing at maximum 300mm centres. Counterbattens prevent water collecting behind the tile battens and protect the nail tape from foot traffic during construction. They should be 50mm wide and can be any thickness from 10mm.

Fix tile battens over the counterbattens, nailing using 65 x 3.35mm smooth round steel nails.

Joints should be square cut; butted centrally on counterbattens and must not occur more than once in any group of four battens on any one rafter.

(Refer to the Sandtoft installation guide for battens)

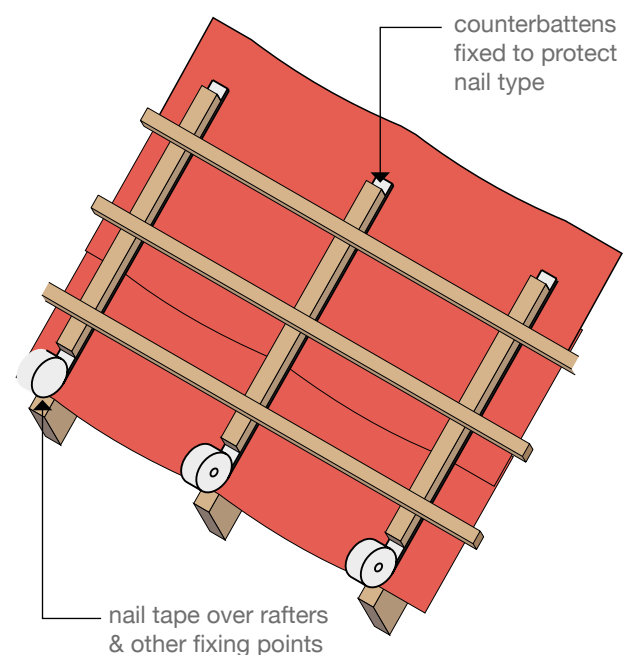

USING NAIL TAPE WITHOUT COUNTERBATTENS

If installing nail tape without counterbattens, then it is necessary to fix short strips directly under the battens and other fixings.

Firstly, mark out the positions of the battens using a chalk line. Position the nail tape at the chalk lines, directly over the rafters and other fixing points. Then position the battens to the chalk lines and nail through the nail tape into the rafters.

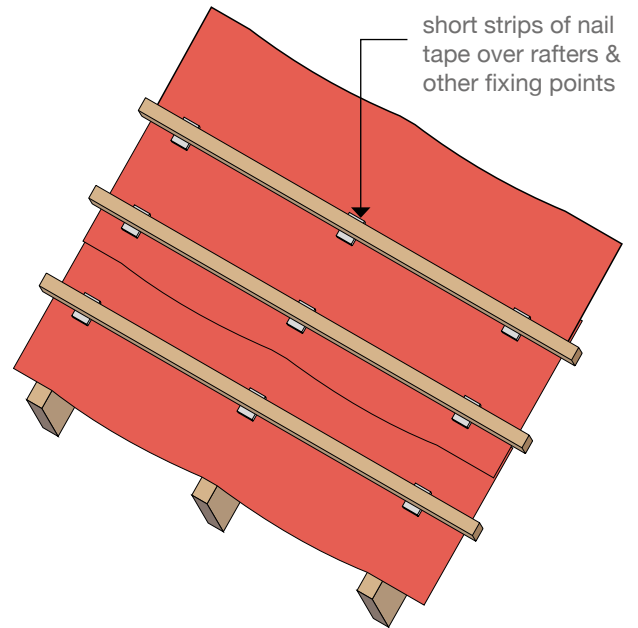

VENTILATED EAVES

(Product Ref: 2452939047)

Set the fascia height, including over fascia ventilator if required, to ensure a fall to the underlay support tray. If this means the eaves course tiles cannot be set to the same angle as the tiles above then it will be necessary to fix a ventilator strip or tilt batten over the underlay support tray. A batten must be notched to allow free flow of water from underlay to gutter (*see detail*).

Fix spacer trays continuously to ensure free passage of air between the underlay and insulation at wall plate. If necessary, depending upon depth of insulation, fix additional spacer trays (available separately).

Lay underlay support trays over the fascia, overlapping each by 100mm. Seal the laps between underlay support trays using Sandtoft MultiFix adhesive (Product Ref: 6180005).

Lap the underlay over the underlay support trays by at least 150mm. Use MultiFix adhesive or double sided tape to seal the underlay to the underlay support trays.

Position the first tile batten so that tiles overhang the gutter by 45 to 55mm. Nail all eaves course tiles and clip if required by the fixing specification.

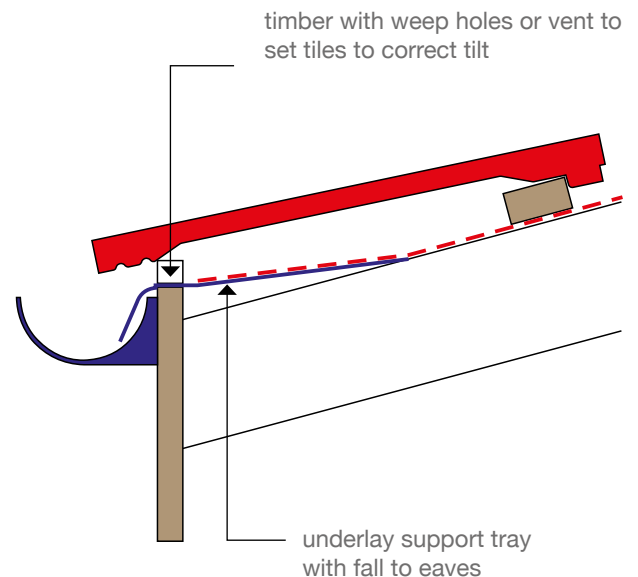

ROOF WINDOW

Install the roof window surround in accordance with its manufacturer's instructions. Turn the general underlay up against and tape to the window surround using Sandtoft Multi-tape. Seal the underlay at each window corner using Sandtoft Multi-tape.

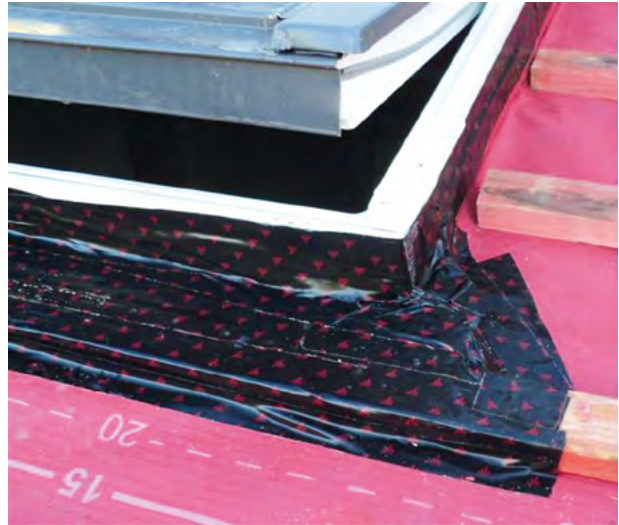

Where available, install a secondary underlay skirt around the window.

Alternatively, form a skirt from Sandtoft VPM Super underlay. Make a cut in the general underlay above the window to create a lap over the skirt and seal with Sandtoft Multi-tape. Seal the skirt over the tiling battens and general underlay using Sandtoft Multi-tape.



Install the roof window flashings in accordance with its manufacturer's recommendations.

Install the tiling over the window flashings. Where necessary at the side flashings, carefully remove tile nibs to reduce 'kicking' over the flashings. Use stainless steel screws, instead of nails, to secure all tiles over the window flashings.



SANDTOFT TECHNICAL SUPPORT

T 0844 9395 999

E sandtofttechnical@wienerberger.com

Sandtoft Roof Tiles

Belton Rd

Sandtoft

Doncaster

DN8 5SY

T 0844 9395 900

F 0844 9395 950

sandtoftorders@wienerberger.com

www.wienerberger.com



Wienerberger

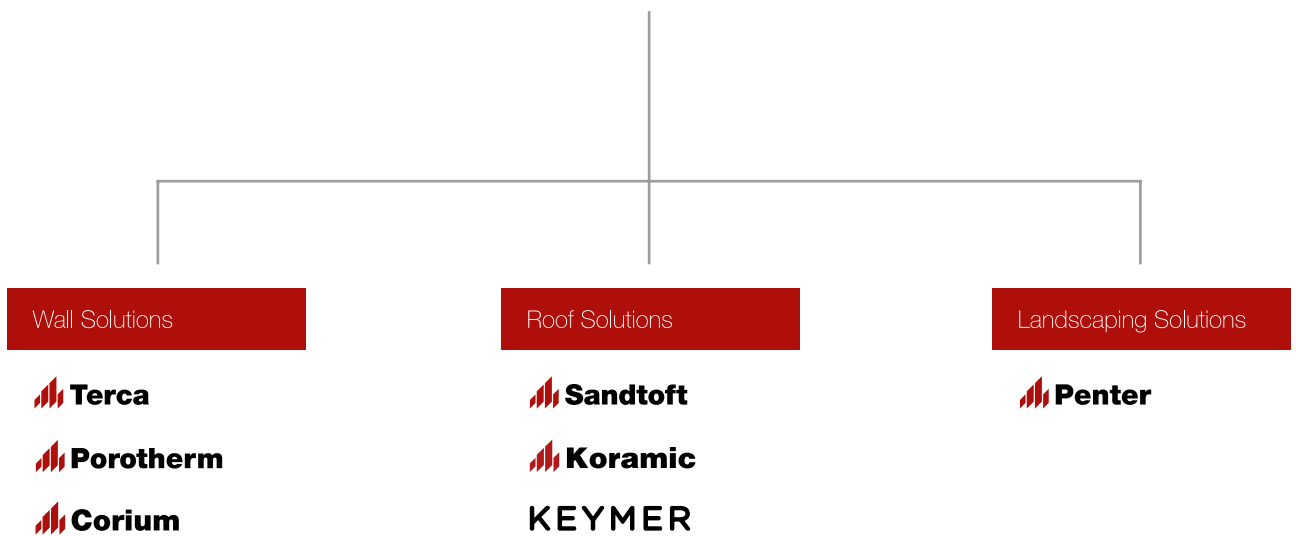

Wienerberger Ltd
Wienerberger House,
Brooks Drive
Cheadle Royal Business Park
Cheadle, Cheshire
SK8 3SA

☎ T: 0161 491 8200
F: 0161 491 6529

✉ ukmarketingcommunications@wienerberger.com

🐦 [@wienerbergeruk](https://twitter.com/wienerbergeruk)

🌐 www.wienerberger.co.uk

